

Technical specifications

Cumbria Levant straight stairlift

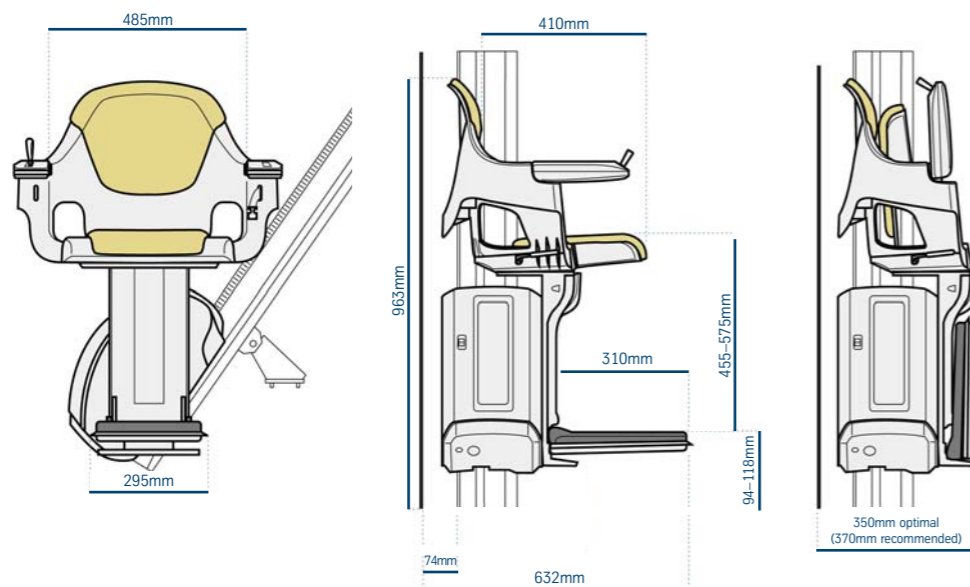

Extensive Product Range

Lift Able can provide quotations for an extensive range of access equipment including straight and curved stairlifts, domestic Through the floor and step lifts, vertical and inclined platform lifts.

After Sales Service & Peace of Mind

Lift Able are the acknowledged leaders in stairlift customer service and it is the foundation of our success and reputation.

Our Service Desk

On call 24 hours a day, 365 days a year our telephone helpline (01642) 763646 is always manned by experienced and caring staff. You can rest assured that with Lift Able you will benefit from years of experience and dedication in providing our customers with a first class service.

Product Warranty

All our products come with a 12 months fully comprehensive warranty as standard. Extended warranties and service packages are available, please call our Service Desk for further details.



The photos, drawings and other information are simply an indicator and could be modified without any notice.

Lift Able

Head Office: Easter Park, Earlsway,
Teesside Industrial Estate, Stockton-on-Tees TS17 9NT
Branch Office: 236 Europa Boulevard,
Gemini Business Park, Warrington, Cheshire WA5 7TN
Enquiries: +44 (0)1642 768590
Service: +44 (0)1642 763646
Fax: +44 (0)1642 766590
Email: sales@liftable.co.uk
www.liftable.co.uk



Lift Able



ThyssenKrupp

Levant really is the next generation stairlift

the levant's design is simple, sturdy and above all matches most accessibility requirements



Options

- Fully automatic folding hinge.
- Heavy duty option up to 146kg.

Seat

The ergonomically designed seat makes the ride smooth and comfortable. The seat is wide providing spacious seating. When the lift is folded up, there is still plenty of space for other stair users.

Padding

The thick and luxurious padding ensures a firm but soft seat. The sisal colour of the padding is a neutral colour which will match with any internal décor. The upholstery is fire retardant, liquid repellent and easy to clean.

Seat Belt

A seat belt as standard gives the user maximum security whilst travelling on the lift and is an easy-to-use one click system.

Swivel Lever

The swivel lever is very easy to use, swivelling the seat safely away from the staircase towards the upper hall landing, allowing the user to get off the lift safely. The swivel lever is situated on the right and left side of the chair.

Footrest

The footrest is large and enables the user to place their feet comfortably for travelling on the lift. The darker colour on the top of the footrest ensures, stains or smudges from shoes won't show easily on this darker colour.

Rail

The aluminium rail has a slim design which gives it a modern look.

Always Put Customer Service First

As one of only a few manufacturers who are members of LEIA (Lift and Escalator Industry Association) you can have complete peace of mind, safe in the knowledge that you have chosen a company who have built a long and enviable reputation as a manufacturer.

'who always put customer service first'.

Features

- Lifting capacity 127kg–138kg.
- Operation, joystick control (also functions as key).
- Infa red call and send station with push button.
- Drive system: battery (24VDC), rack and pinion drive system.
- Rail: anodised aluminium.
- Angle: 28° up to 53°.
- Excellent value for money.
- Can be re-sited as not handed.
- Aesthetically pleasing with modern design.
- Neutral colour.
- EN81-40 certification.



Specialists in
Access Solutions