

Technical specifications

Cumbria Comfort Straight stairlift

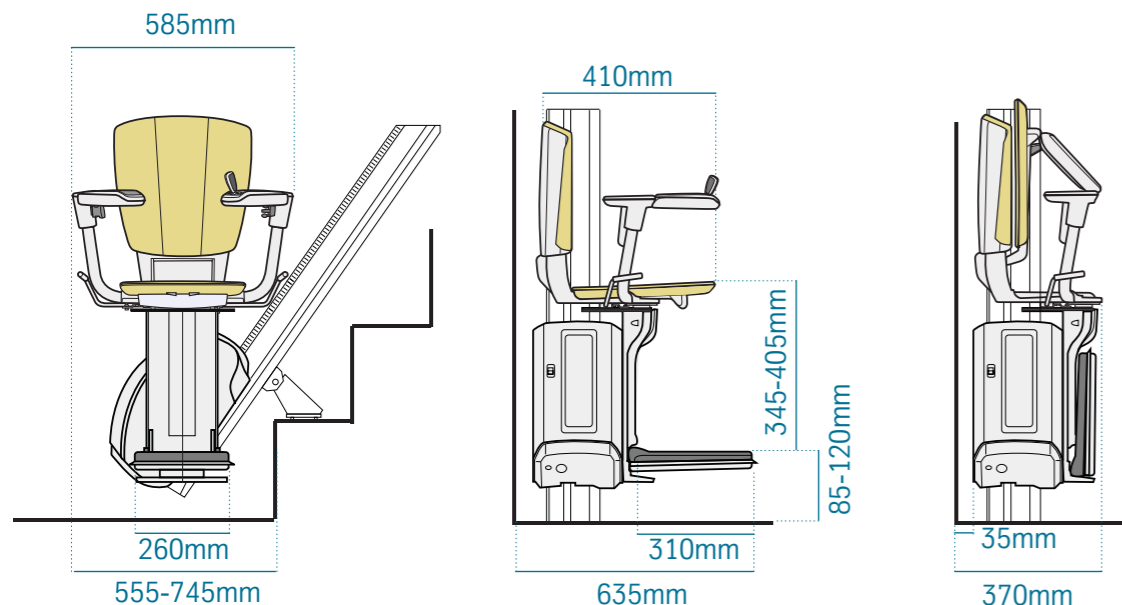

Extensive Product Range

Lift Able can provide quotations for an extensive range of access equipment including straight and curved stairlifts, domestic Through the floor and step lifts, vertical and inclined platform lifts.

After Sales Service & Peace of Mind

Lift Able are the acknowledged leaders in stairlift customer service and it is the foundation of our success and reputation.

Our Service Desk

On call 24 hours a day, 365 days a year our telephone helpline (01642) 763646 is always manned by experienced and caring staff. You can rest assured that with Lift Able you will benefit from years of experience and dedication in providing our customers with a first class service.

Product Warranty

Extended warranties and service packages are available, please call our Service Desk for further details.

Vinyl upholstery colour options available:

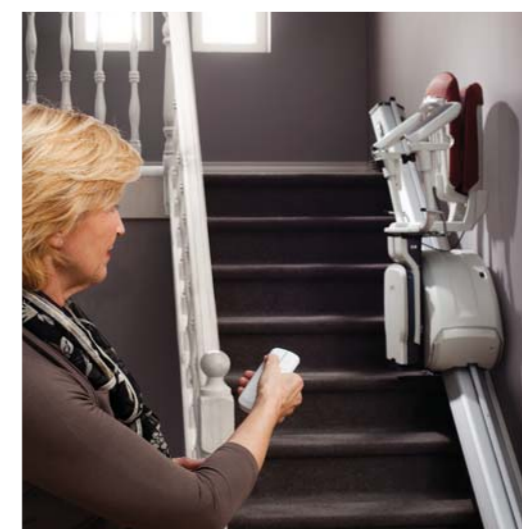

The photos, drawings and other information are simply an indicator and could be modified without any notice.

Lift Able

Head Office: Easter Park, Earlsway,
Teesside Industrial Estate, Stockton-on-Tees TS17 9NT

Branch Office: 236 Europa Boulevard,
Gemini Business Park, Warrington, Cheshire WA5 7TN

Enquiries: +44 (0)1642 768590

Service: +44 (0)1642 763646

Fax: +44 (0)1642 766590

Email: sales@liftable.co.uk

www.liftable.co.uk



Lift Able



ThyssenKrupp

Cumbria Comfort the stairlift with finesse



Options

- Fully Automatic Folding Rail
- Powered Swivel Seat
- Heavy Duty up to 146kg
(all powered options available with Heavy Duty option)
- 5 Seat Height Adjustments

Design Meets Comfort

Cumbria Comfort stairlift for indoor straight staircases offers outstanding design from chair to rail together with high functionality and comfort. The chair has been awarded the "Rehacare Design Award 2008/2009 Good Design" and meets the highest aesthetic requirements. The Cumbria Comfort is quick and easy to install and combines reliable tried-and-tested technology with modern design and comfort at a competitive price.

The seat is ergonomically designed and generously upholstered, has a linked seat and footrest, with an integral, retractable safety belt as standard.

The curved foldable arm rests and retractable safety belt deliver security when travelling on the stairlift.

Cumbria Comfort has a choice of four different seat upholstery colour options which blend perfectly with different décors.

Reliable Easy to Use Technology

Cumbria Comfort is operated by a joystick control, which has been designed in consultation with occupational therapists. The joystick control is simply pushed in the required direction to move the stairlift up or down the stairs. For safety reasons the joystick can be removed to prevent unauthorised use. The stairlift is recharged automatically at the upper and lower stops to ensure the stair lift is always ready for use. An arrival alert indicates that the lift has arrived at the top landing and it is safe to get off the stairlift.

Cumbria Comfort has armrests and a footrest that can be folded away when not in use, to keep the stairs free for other users. The stairlift can also be "called" and "sent" by remote control so that it can be parked out of the way or used by more than one person.

Highest Standards of Safety

Cumbria Comfort meets the most stringent safety standards in the industry, and conforms to the latest European Standard EN 81-40.

Always Put Customer Service First

As one of only a few manufacturers who are members of LEIA (Lift and Escalator Industry Association) you can have complete peace of mind, safe in the knowledge that you have chosen a company who have built a long and enviable reputation as a manufacturer

'who always put customer service first'.



Features

- Angle: 28° – 53°
- Curved armrests
- Retractable safety belt
- Load capacity: 125 kg
- Award winning design
- Seat interlink as standard
- Choice of stairlift controls
- Rack and pinion drive system
- Manual swivel seat as standard
- A choice of 4 different seat upholstery colours
- Seat, footrest and armrests can be folded away
- Power supply: battery (24V) with charge stations
- Rail, straight aluminum, anodized – length: max. 7.5 m
- Ergonomic seat with large footrest and curved arm rests

Specialists in
Access Solutions